



# ActiveOffice



The Active Office exercise desk bike makes it simple to incorporate movement

and exercise into your daily work life. The bike is designed for all-day riding comfort and includes foot rests for the time you choose not to pedal. Track the miles and hours you ride, the calories you burn and your heart rate with the included console. Syncs with tablets and smart phones.

**KEEP MOVING!!**

**Model CC-1**

**Console  
Controlled  
Exercise  
Bike**



Requires stand-up desk, purchased separately

[www.ActiveOfficeUSA.com](http://www.ActiveOfficeUSA.com)

8" X 10" console base  
takes minimal space  
on desk top

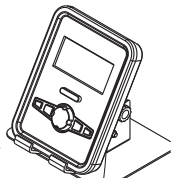

Large padded  
seat provides  
all day riding  
comfort. Seat  
adjusts 5 inches  
horizontally & 18  
inches vertically.

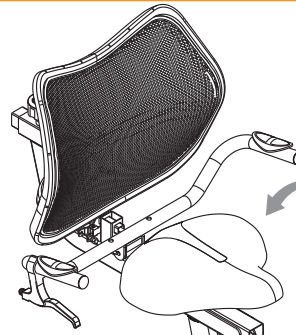

7 foot long cord  
connects console  
to the bike

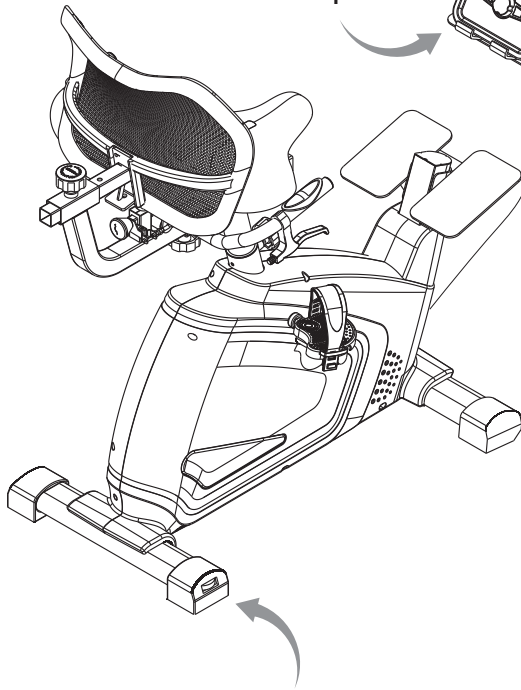

Resistance is provided  
by a 13 pound magnetic  
fly-wheel with a smooth  
and silent belt  
transmission system

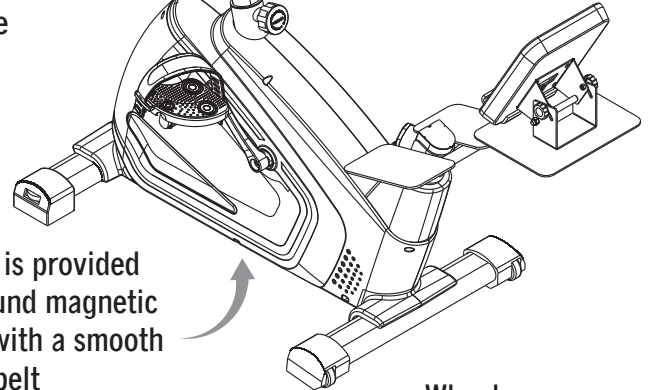

Wheels on  
front base  
provide for  
easy transport.

Broad foot base  
provides stable  
and safe riding.

Heart rate bar  
syncs with console  
to provide pulse rate.

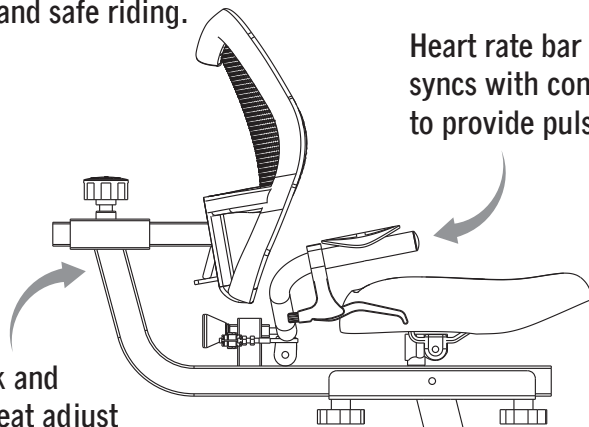

Seat back and  
padded seat adjust  
to accommodate people  
of all weight and height

Each foot is adjustable  
to accommodate  
variations in floor heights.

Generous slip resistant  
foot rests assist with entry  
and exit of bike and provide  
comfortable place to rest feet  
between riding sessions.

Maximum rider  
weight = 265 pounds

Bike weight = 74 pounds

Warranty = 1 Year

